

OMEGA[®]
FOODTECH



GC 300 - GC 350



AFFETTATRICI A GRAVITÀ
 Costruite in lega di alluminio trattata con ossidazione anodica.
 Affilato incorporato.
 Tramissione a cinghia Poly V.
 Per il dettaglio alimentare e la ristorazione collettiva.
 Macchine rispondenti alla Direttiva Macchine 98/37 CEE.
 Comandi con dispositivo N.V.R.

GRAVITY SLICING MACHINES
 Made of aluminium alloy treated with anodic oxidation.
 Built-in sharpener.
 Poly V belt drive.
 For food retail and collective catering.
 Machines comply with Machine Directive 98/37 EEC.
 Controls with N.V.R. device.

SCHWERKRAFT-AUFSCHNITTMASCHINEN
 Ausgeführt aus Aluminiumlegierung, poliert und eloxiert.
 Eingebaute Schleifvorrichtung.
 Riemenantrieb Poly V.
 Für Lebensmitteleinzelhandel und Großgastronomie.
 Die Maschinen entsprechen der Maschinenrichtlinie 98/37/EWG.
 Ein-Aus Drucktaste.

TRANCHEUSES À GRAVITÉ
 Réalisées en alliage d'aluminium traité par oxydation anodique.
 Aiguiseur incorporé.
 Transmission à courroie Poly V.
 Pour le détail alimentaire et la restauration collective.
 Machines conformes à la Directive machines 98/37 CEE.
 Boutons Marche-Arrêt.

CORTADORAS DE FIAMBRES A GRAVEDAD
 Costruidas en aleación de aluminio tratada con oxidación anódica.
 Afilador incorporado.
 Transmisión a correa Poly V.
 Para venta minorista de alimentos y restauración colectiva.
 Máquinas conformes a la Directiva Máquina 98/37 CEE.
 Mandos con dispositivo N.V.R.

Specifiche tecniche / Technical specifications

	GC 300	GC 350
diametro lama, diameter of the blade, Klingedurchmesser, diametre de la lame, diametro de la cuchilla	300 mm	350 mm
motore, motor, Motor, moteur, motor	0,37 (0,50) kW (HP)	0,37 (0,50) kW (HP)
corsa carello, carriage stroke, Schilittenweglauf, course du chariot, corsa del carro	325 mm	325 mm
ampiezza taglio, cut, Schnittgröße, ampleur de coupe, amplitud de corte	220 mm	260 mm
ampiezza taglio, cut, Schnittgröße, ampleur de coupe, amplitud de corte	270x190 mm	270x200 mm
spessore taglio, cut thickness, Schnittstärke, epaisseur de coupe, espesor de corte	0/15 mm	0/15 mm
peso netto, net weight, Nettogewicht, poids net, peso neto	30 kg	31 kg

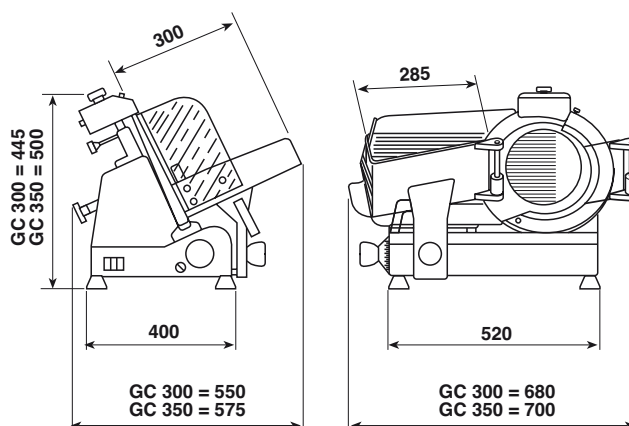

Aishwarya Consolidates Pvt. Ltd.,

#19, Frist Floor, 10th 'B' Main, 27th Cross,
 Third Block Jayanagar, BANGALORE - 560 011, INDIA
 Tel: +91-80-2664 1200/1/2 Fax: +91-80-2664 1204

E-mail : aishtek@vsnl.com www.aishwaryaconsolidates.com

Nota: i dati del presente catalogo non sono impegnativi e potranno subire variazioni senza preavviso / Specifications and other features are subject to change without notice (07/12)

